

Amphenol FCI
 2016 AFCl
 ©

PC BOARD VERSIONS		
PRODUCTNR:	PCB THICKNESS	DIM "A"
89038-X01LF	1.6	2.90
89038-X11LF	2.4	3.53

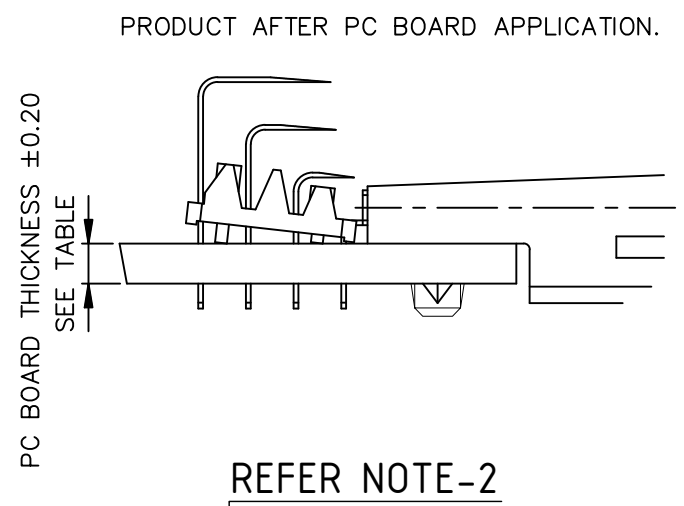

89038-XY1LF

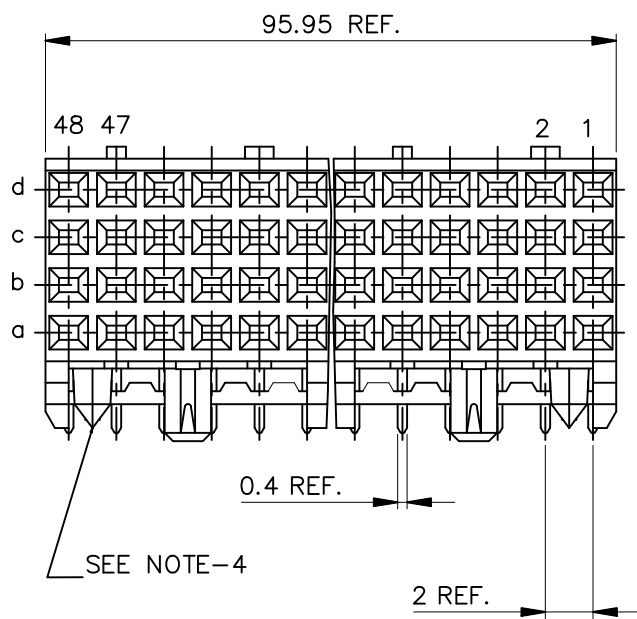
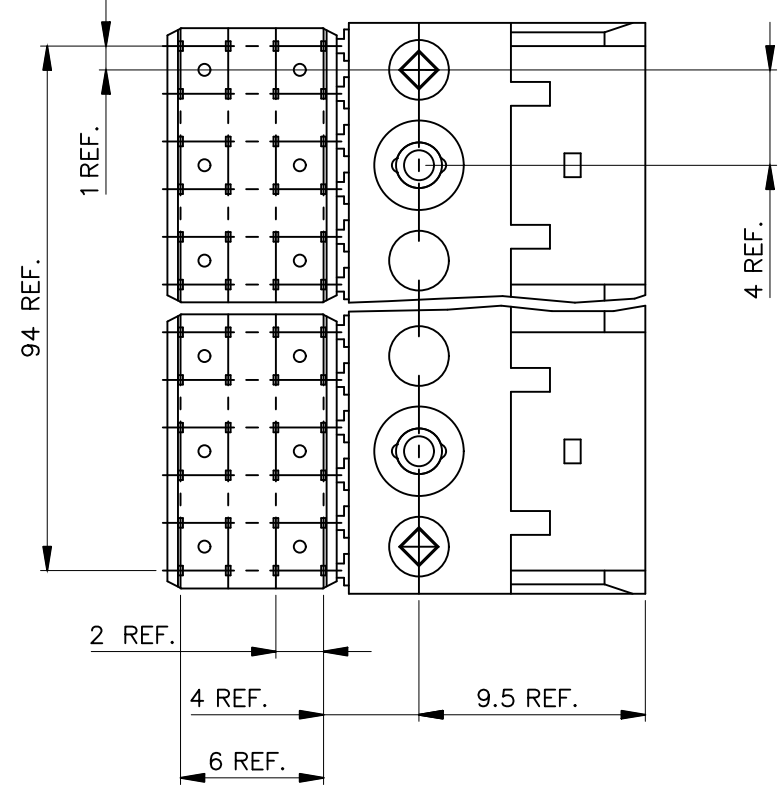
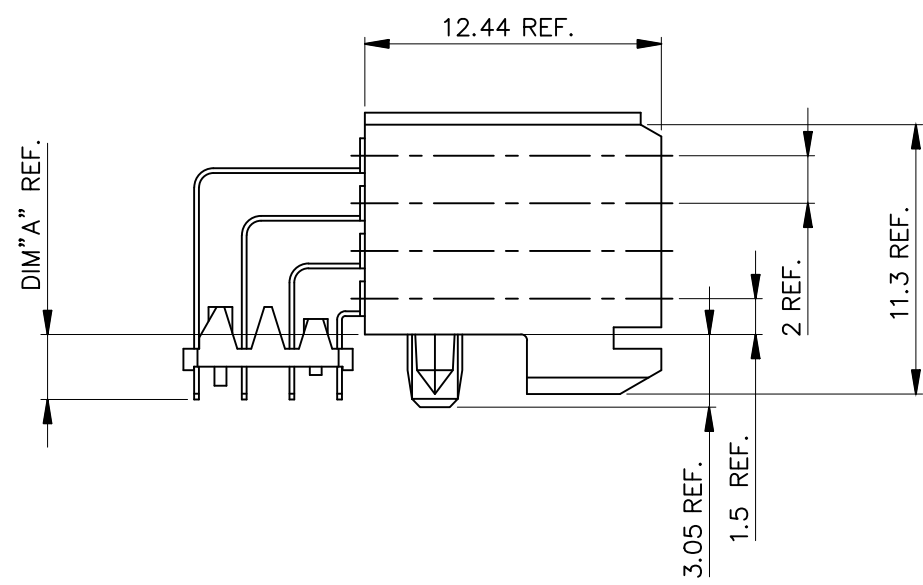
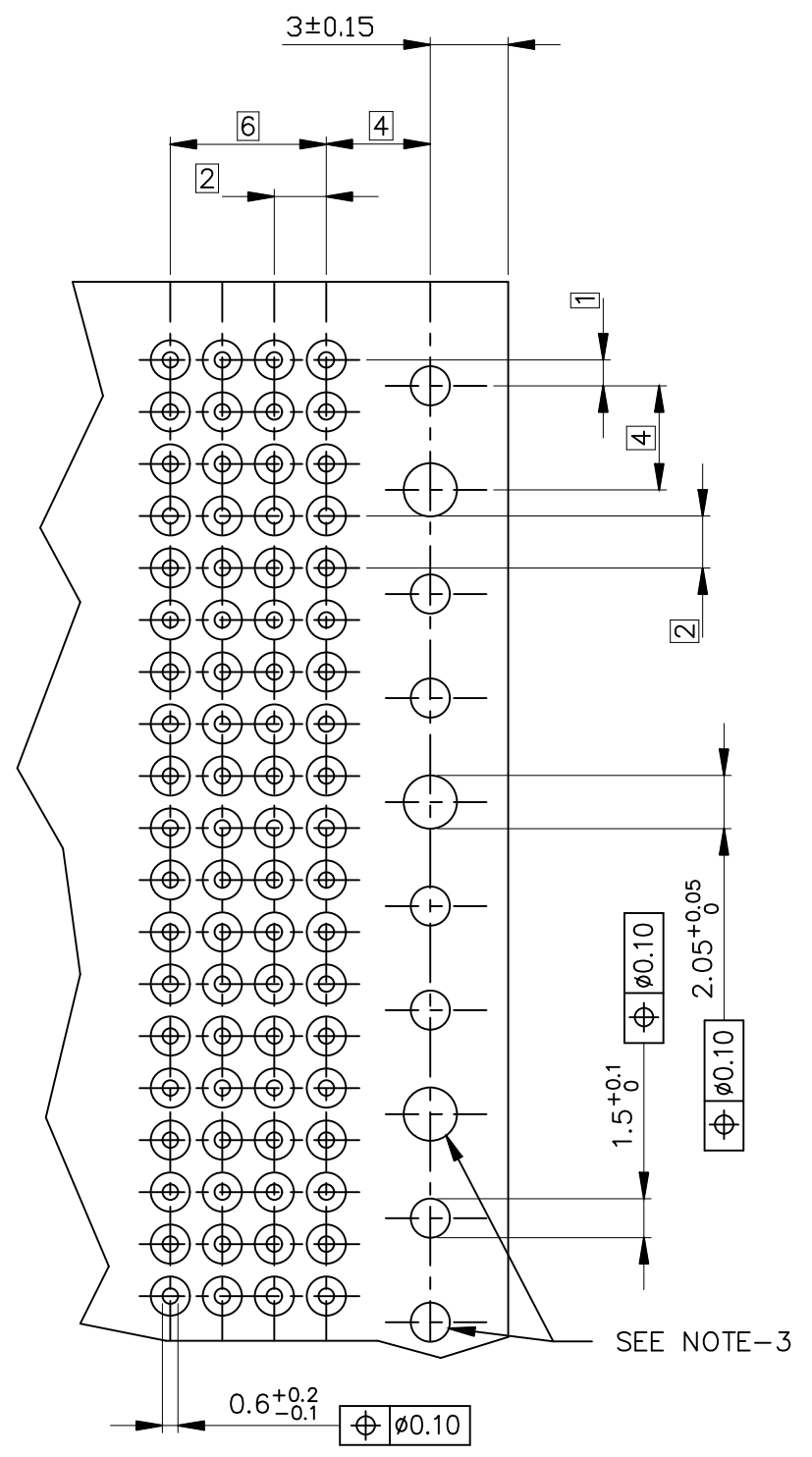

RECOMMENDED HOLE PATTERN, COMPONENT SIDE.

NOTES:

- MATERIAL : BODY : LCP UL94-V0
: CONTACT : COPPER ALLOY.
- FOR PLATING PERFORMANCE REFER DRAWING # 10159408 \triangle
- INDICATED HOLES ARE UNPLATED.
- DIAMOND LOCATION PEG ARE ONLY EXISTED ON THE BOTH SIDES OF PRODUCT.
- THIS PRODUCT MEETS EUROPEAN UNION DIRECTIVES AND OTHER COUNTRY REGULATIONS AS DESCRIBED IN GS-47- 0004.
- THE HOUSING WILL WITHSTAND EXPOSURE TO 260° PEAK TEMPERATURE FOR 10 SECONDS IN A WAVE SOLDER APPLICATION.
- A \triangle SYMBOL WILL BE NEXT TO ANY DIMENSION, VIEW, OR NOTE WHICH HAS BEEN MODIFIED WITH THE CURRENT DRAWING REVISION.

mat'l. code				surface	tolerance	projection	product family		
				ISO 1302	ISO 406	ISO 1101	METRAL		
ltr	ecn no	dr	date	tolerances unless otherwise specified			title		
M	DG08-0171	TER	2008-08-26	angles	linear	.X±0.3	RA FEMALE SIGNAL		
N	DG09-0068	CENH	2009-03-03	0°±2°		.XX±0.13	96 mm PRESS PEG		
P	ELX-I-38913	MINI	2020-10-23			.XXX±0.050	scale -		
				dr	H. BOUWKNGET	1993-02-02	dwg no		
				enr	ARUN	2020-10-23	sheet 1 of 3		
				chr	ALEX BABU	2020-10-23	size		
				appd	SANOJ	2020-10-23	A3		
sheet index		revision	P	P	P	type			
		sheet	1	2	3	Product Customer Drawing			

PC BOARD VERSIONS

PRODUCTNR:	PCB THICKNESS	DIM "A"
89038-X02LF	1.6	2.90
89038-X12LF	2.4	3.53

REFER NOTE-2
89038-XYLFF

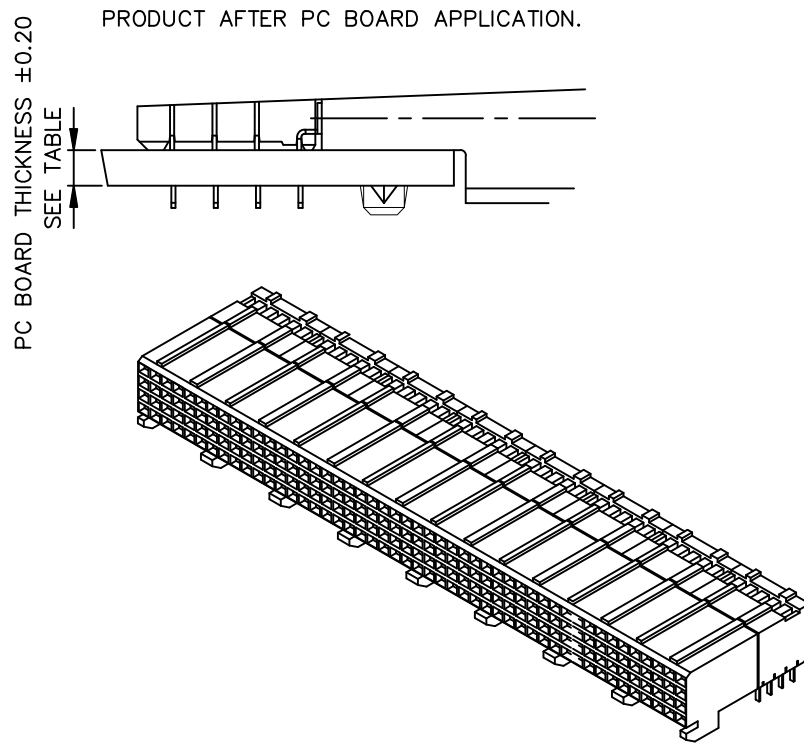
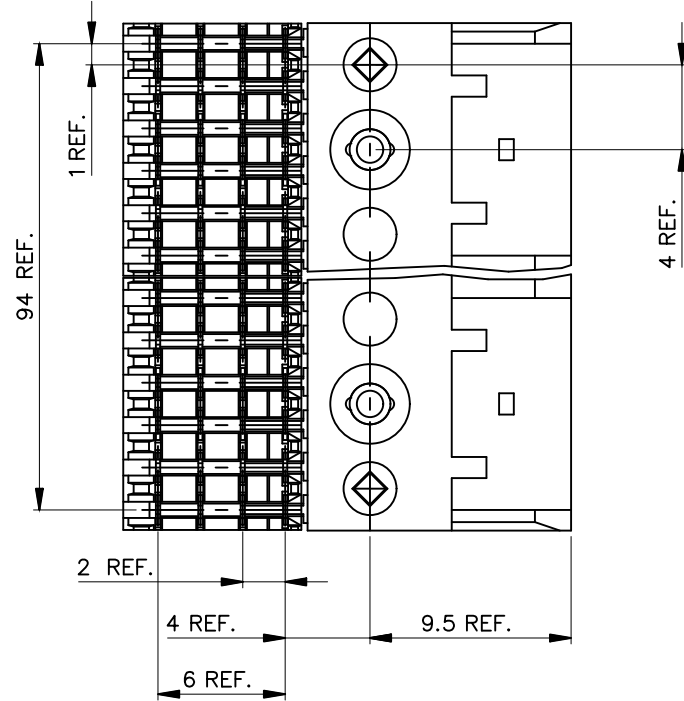
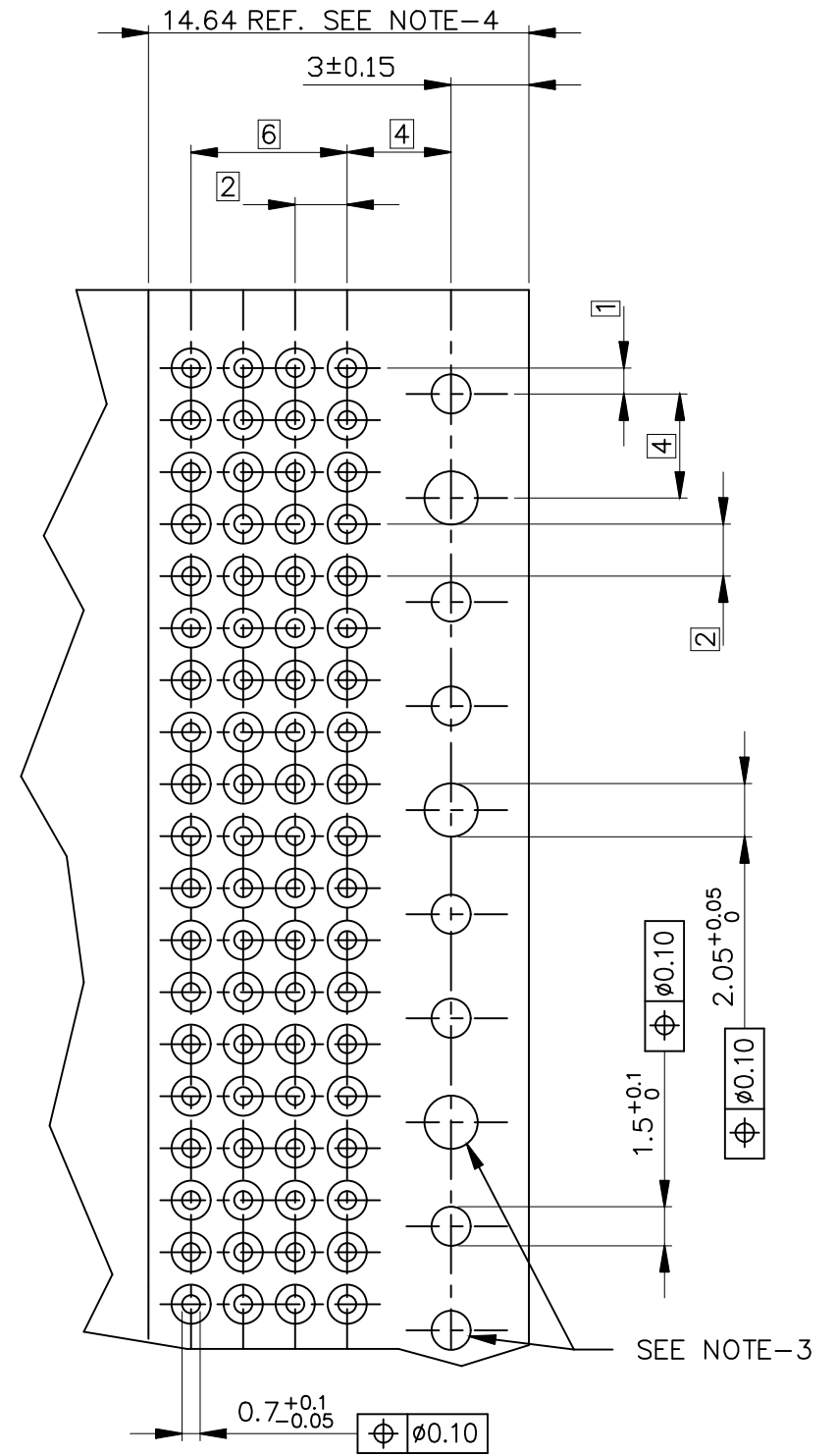
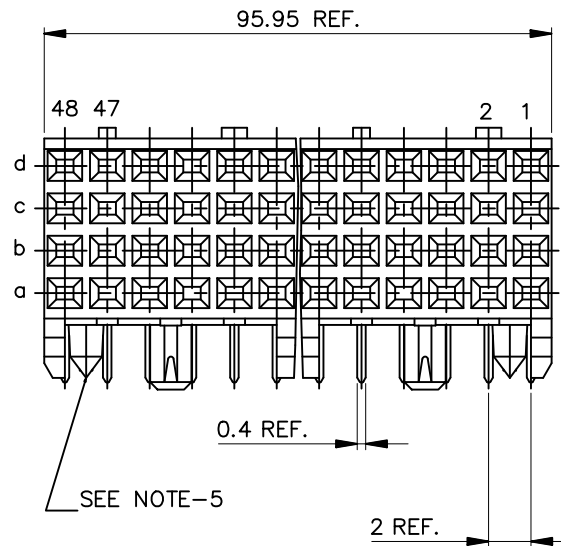
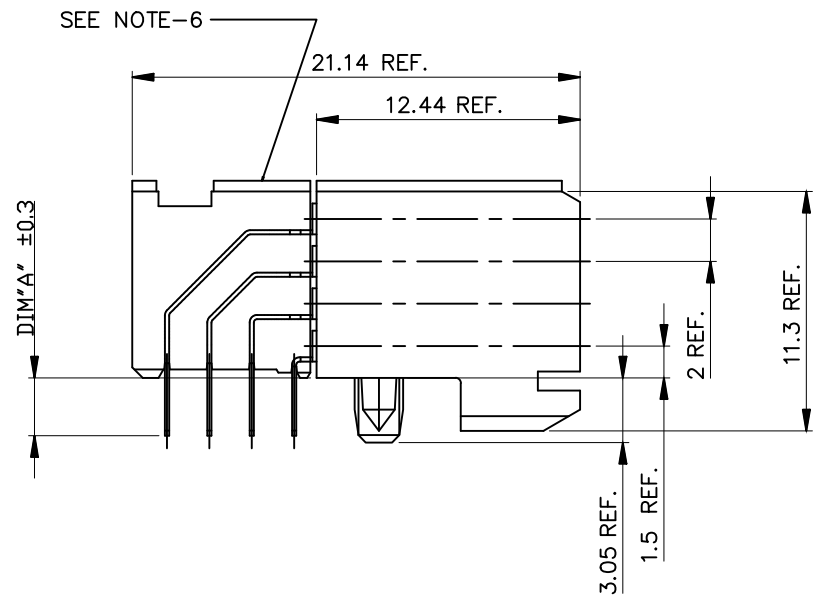

NOTES:

- MATERIAL : BODY : LCP UL94-V0
: CONTACT : COPPER ALLOY.
- FOR PLATING PERFORMANCE REFER DRAWING # 10159408 Δ
- INDICATED HOLES ARE UNPLATED.
- SET BACK FOR PRESS BLOCK.
- DIAMOND LOCATION PEG ARE ONLY EXISTED ON THE BOTH SIDES OF PRODUCT.
- TOP SURFACE OF PRESS BLOCK MAY EXTEND UP TO 0.4MM HIGHER THAN HOUSING.
THIS MAY AFFECT THE TAIL LENGTH BEFORE APPLICATION TO A BOARD
- THIS PRODUCT MEETS EUROPEAN UNION DIRECTIVES AND OTHER COUNTRY REGULATIONS AS DESCRIBED IN GS-47- 0004.
- THE HOUSING WILL WITHSTAND EXPOSURE TO 260° PEAK TEMPERATURE FOR 10 SECONDS IN A WAVE SOLDER APPLICATION.
- A Δ SYMBOL WILL BE NEXT TO ANY DIMENSION, VIEW, OR NOTE WHICH HAS BEEN MODIFIED WITH THE CURRENT DRAWING REVISION.

mat'l. code				surface	tolerance	projection	product family			
				ISO 1302	ISO 406	ISO 1101	METRAL			
ltr	ecn no	dr	date	tolerances unless otherwise specified			title			
M	DG08-0171	TER	2008-08-26	angles	.X±0.3	mm	RA FEMALE SIGNAL 96 mm PRESS PEG			
N	DG09-0068	CENH	2009-03-03	linear	.XX±0.13					
P	ELX-I-38913	MINI	2020-10-23	0°±2°	.XXX±0.050	scale	-			
				dr	H. BOUWKNGET	1993-02-02	dwg no		sheet 2 of 3	size
				enr	ARUN	2020-10-23	89038		A3	
				chr	ALEX BABU	2020-10-23	type		Product Customer Drawing	
				appd	SANOJ	2020-10-23				
sheet index	revision sheet	P 1	P 2	P 3						

Amphenol FCI

2016 AFCl

PC BOARD VERSIONS

PRODUCTNR:	PCB THICKNESS	DIM "A"
89038-X03LF	1.6	2.90
89038-X13LF	2.4	3.53

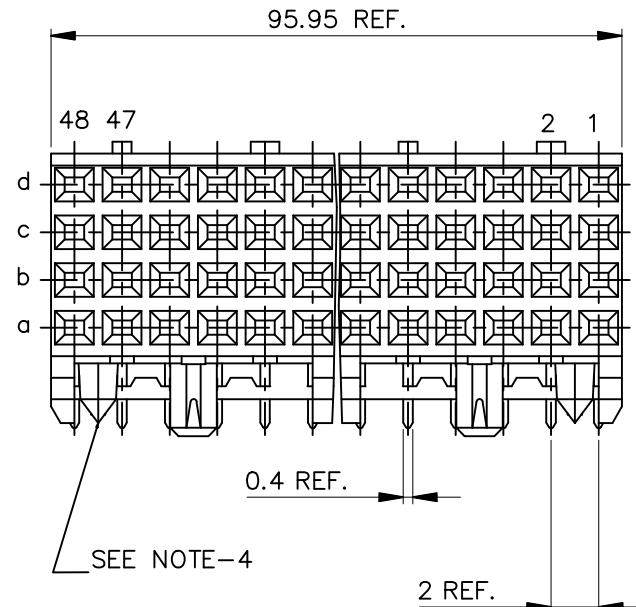
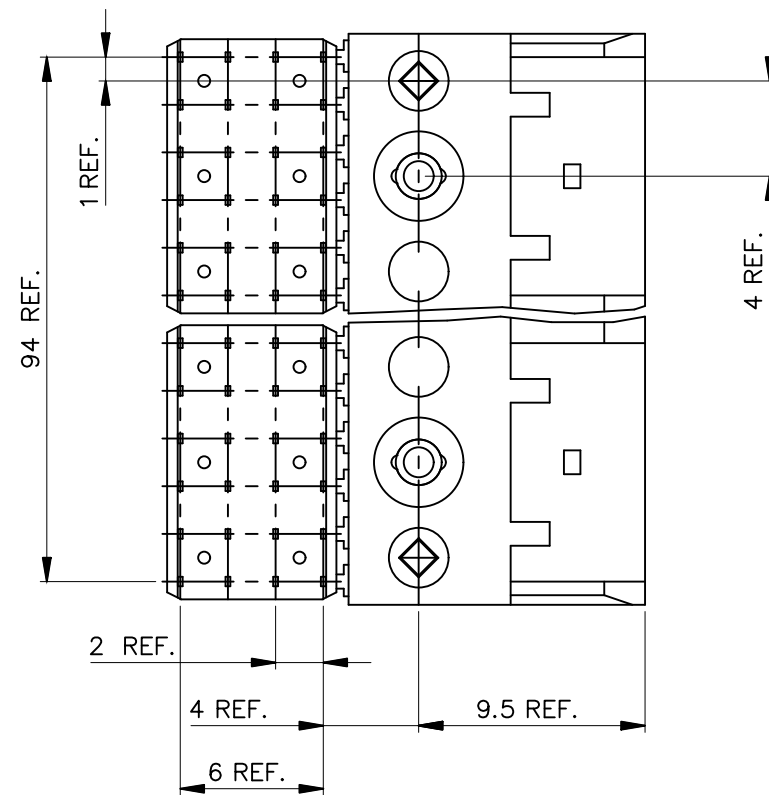
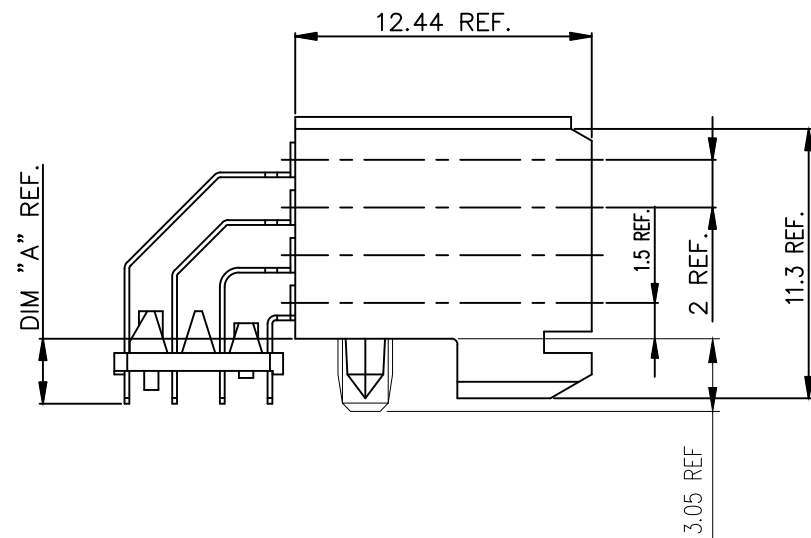

PRODUCT AFTER PC BOARD APPLICATION.

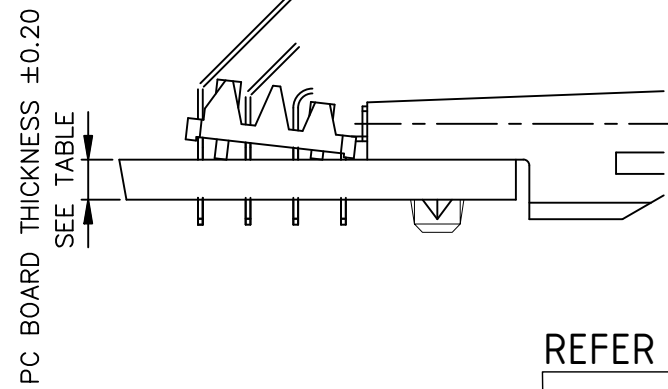

REFER NOTE-2

89038-XYLFF

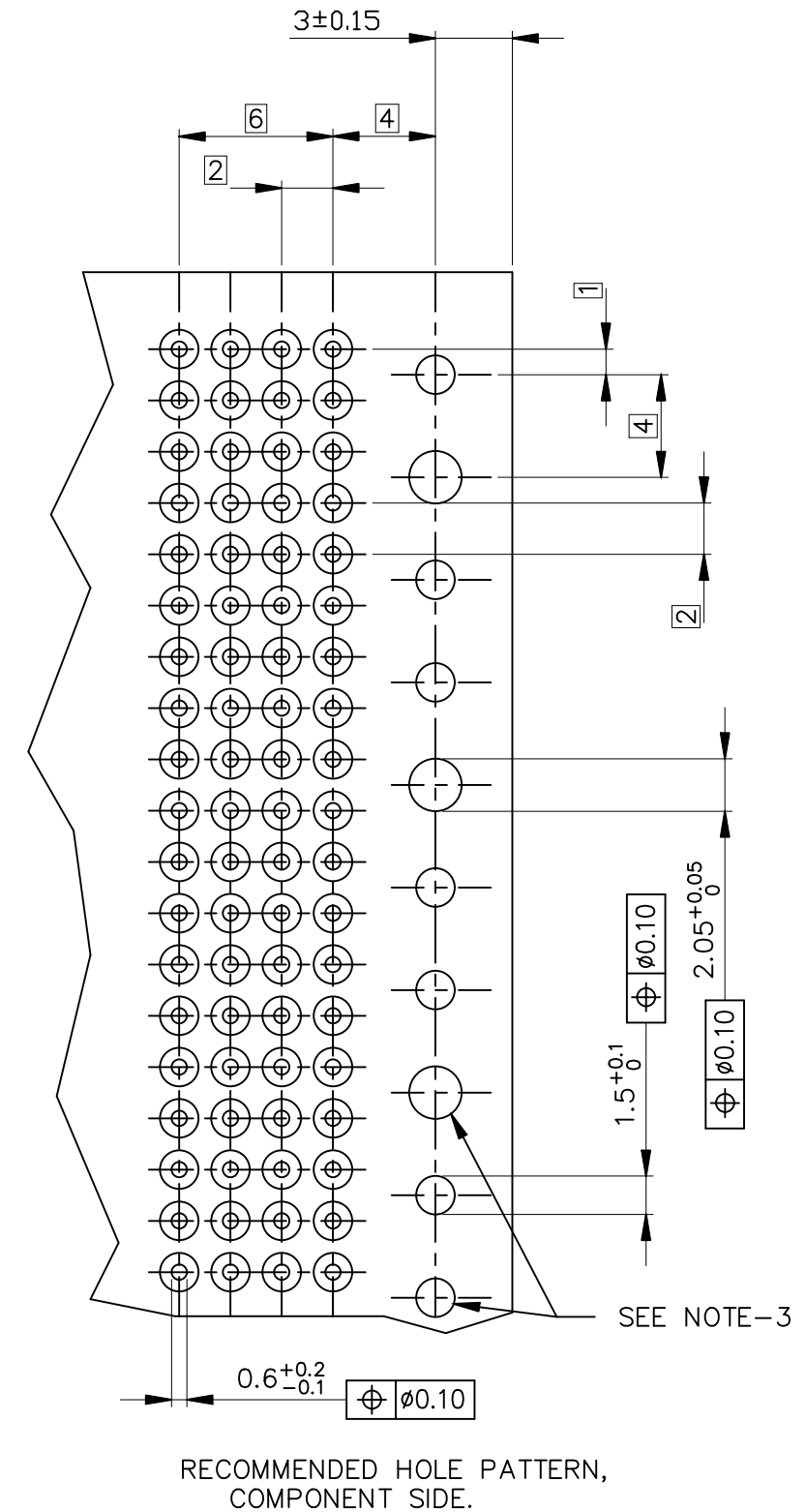

RECOMMENDED HOLE PATTERN, COMPONENT SIDE.

NOTES:

- MATERIAL : BODY : LCP UL94-V0
: CONTACT : COPPER ALLOY.
- FOR PLATING PERFORMANCE REFER DRAWING # 10159408
- INDICATED HOLES ARE UNPLATED.
- DIAMOND LOCATION PEG ARE ONLY EXISTED ON THE BOTH SIDES OF PRODUCT.
- THIS PRODUCT MEETS EUROPEAN UNION DIRECTIVES AND OTHER COUNTRY REGULATIONS AS DESCRIBED IN GS-47- 0004.
- THE HOUSING WILL WITHSTAND EXPOSURE TO 260° PEAK TEMPERATURE FOR 10 SECONDS IN A WAVE SOLDER APPLICATION.
- A SYMBOL WILL BE NEXT TO ANY DIMENSION, VIEW, OR NOTE WHICH HAS BEEN MODIFIED WITH THE CURRENT DRAWING REVISION.

mat'l. code				surface	tolerance	projection	product family				
				ISO 1302	ISO 406	ISO 1101	METRAL				
ltr	ecn no	dr	date	tolerances unless otherwise specified			title				
M	DG08-0171	TER	2008-08-26	angles	linear	.X±0.3	RA FEMALE SIGNAL				
N	DG09-0068	CENH	2009-03-03	0°±2°		.XX±0.13	96 mm PRESS PEG				
P	ELX-I-38913	MINI	2020-10-23			.XXX±0.050	dwg no				
				dr	H. BOUWKNGET	1993-02-02	sheet 3 of 3				
				enr	ARUN	2020-10-23	size				
				chr	ALEX BABU	2020-10-23	A3				
				appd	SANOJ	2020-10-23	type				
				Product Customer Drawing							
sheet index	revision sheet	P	P	P							
		1	2	3							